

RELEASE

DATE:

COMPANY:

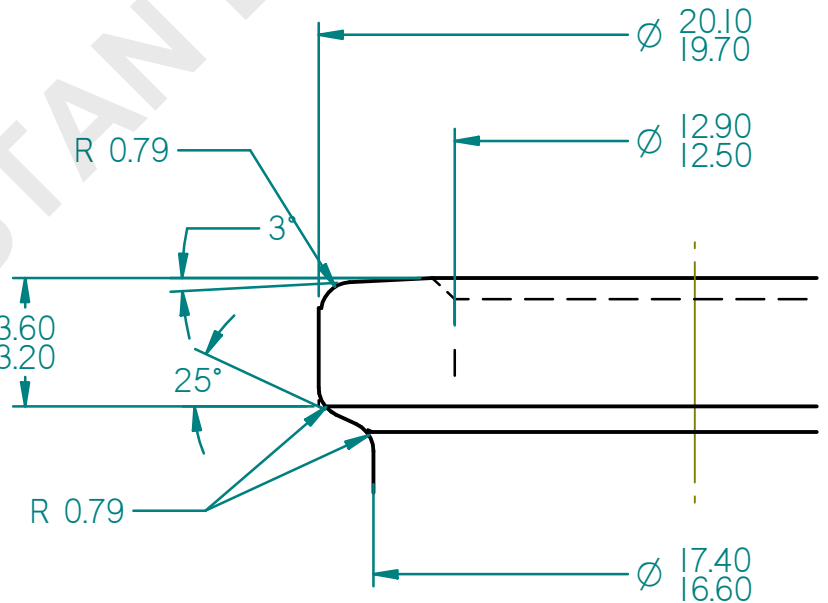
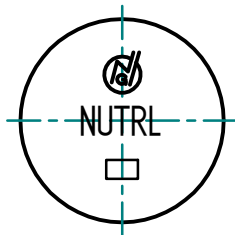
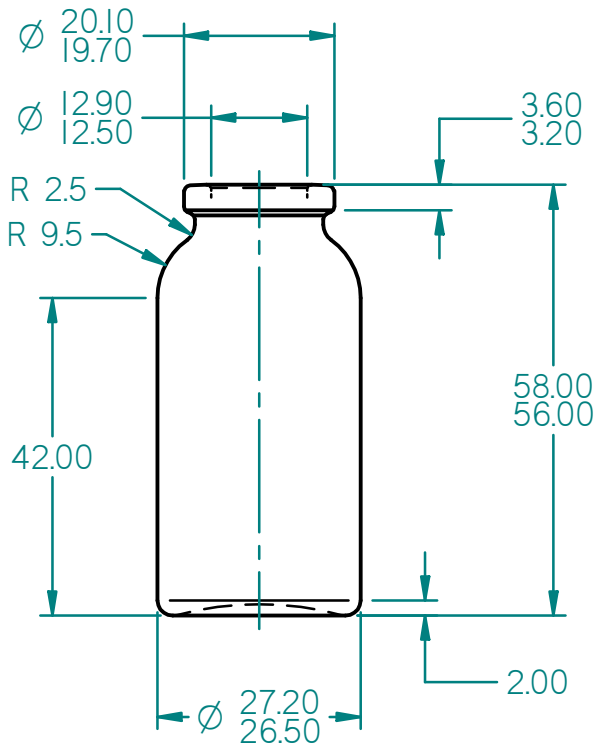

FINISH : 20 mm STD.

Protective note ISO 16016 observed

GENERAL TOLERANCES DIN 6129-1 (DIMENSIONS WITHOUT TOLERANCES ARE FOR REFERENCE ONLY)				FINISH: 20 mm STD.		O'FLOW CAPACITY: 18.50 - 20.50 ml		ARTICLE NO.:			
				FINISH DWG: NA		WEIGHT: 23 g Approx.		5152072100			
				FINISH MOLD NO: 910		TYPE OF GLASS: I COLOUR: FLINT					
				DATE	NAME	TITLE: <h2 style="text-align: center;">15 mL VICTORY</h2>					
				DRAWN	21/11/2013					Paresh	
				CHECKED	21/11/2013					H.B.P.	
				SCALE	1 : 1, 5 : 1						
				 NEUTRAL GLASS & ALLIED INDS. PVT. LTD. MUMBAI / KOSAMBA			MOLD NO.:	DRAWING NO.:	REVISION	SHEET	FORMAT
							043	B 2072	0	1 OF 1	A4
REV.	CHANGE	DATE	NAME	FILE: 15 mL VICTORY.dft							